



FJ2 Crane Scale



FJ2 Crane Scale

Features:

- Use high speed 24 bits AD. Display reading speed faster to save time and increase work efficiency
- Easy operation and rugged aluminum alloy construction.
- Overloading safety much better than similar products
- 360° rotatable crane hook design for better stability and safety
- Special structure design to guarantee the accuracy
- Use High Brightness LED for easy reading
- Auto-zero tracking, quick zeroing speed to fully improve stability and efficiency
- Selectable 2 units from kilogram (kg), pound (lb) and ton (t)
- Manual/auto/peak weight hold function, set point control function
- Energy-saving design, one charge can be last up to 120 hours
- Low power indication and auto power off for longer operation time
- Special circuit protection design to avoid battery damage
- Easy to replace rechargeable battery without disassembling the scale
- Remote control included with control distance about 30 m

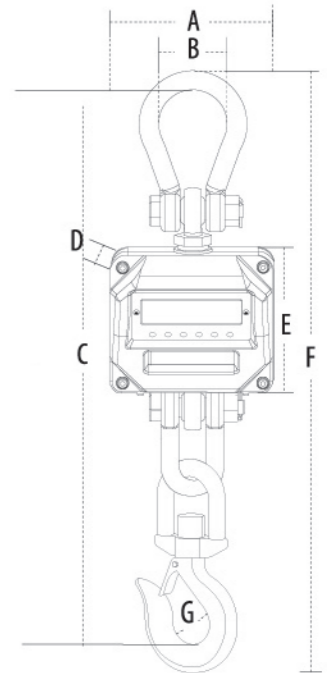

Rugged alloy housing



Adjustable sun visor



Dimensions:

	0.3t~3t	5t	7.5t	10t	15t
A	210	210	210	210	210
B	87	74	74	98	98
C	615	542	542	670	670
D	216	216	216	278	278
E	141	141	141	141	141
F	665	620	650	780	780
G	51	64	64	83	100

360° rotatable crane hook

Options:

- Adjustable sun visor: see more clearly under strong sunlight
- Wireless remote display/control available soon

Specifications:

MODEL	CAPACITY	DIVISION	RESOLUTION
FJ3 - 300kg	300 kg	0.1 kg	1/ 3,000
FJ3 - 600kg	600 kg	0.2 kg	1/ 3,000
FJ3 - 1t	1t	0.5 kg	1/ 2,000
FJ3 - 1.5t	1.5t	0.5 kg	1/ 3,000
FJ3 - 2t	2t	1 kg	1/ 2,000
FJ3 - 3t	3t	1 kg	1/ 3,000
FJ3 - 5t	5t	2 kg	1/ 2,500
FJ3 - 7.5t	7.5t	2 kg	1/ 3,750
FJ3 - 10t	10t	5 kg	1/ 2,000
FJ3 - 15t	15t	5 kg	1/ 3,000

Operating Temperature: -10° C ~ 40° C (14°F ~ 104°F)

Power Source: AC 110V / 230V (± 10%) + DC 6V / 10AH rechargeable battery

Display: LED, 5 digits, height 25.4 mm



EXCELL PRECISION CO., LTD.

6F, No.127, Lane 235, Pao-Chiao Road, Hsin Tien, Taipei Hsien, 231, Taiwan
 Tel: +886-2-89191000 Website: www.excell-scale.com
 Fax: +886-2-89191177 E-mail: sales@excell-scale.com